

Standard Features

HPE Edgeline EL20 Intelligent Gateway Series



Is your company struggling with moving analytics to the edge of your network?

HPE Edgeline Gateways enable organizations to rapidly acquire, analyze and take action on real-time data as it's being collected for additional analysis at a later stage. Bringing computing and analytics close to the edge accelerates the speed of your decision making and reduces the chance of lost opportunities or a missed red flag. HPE Edgeline Gateways are a perfect complement to the industry's first HPE Edgeline Converged Edge Systems for expanding your Internet of Things (IoT) infrastructure beyond traditional data center confines and to enable true edge computing.

The HPE Edgeline EL20 Intelligent Gateway is rugged performance-optimized edge gateway with additional features and higher compute capabilities to tackle more demanding large data volume deployments at the edge itself. It is optimally configured with CPU, memory, connectivity and an expansion I/O selection, including four port Power over Ethernet (PoE) plus 8-bit digital input/output (DIO), to address a host of IoT needs. HPE Edgeline Intelligent Gateways are designed to operate in harsh edge environments, such as such as manufacturing plants, oil and gas facilities and power stations, where wide operating temperature ranges, tolerance for high levels of shock/vibration and resilience against ingress are the norm. These gateways are complete solutions out-of-the-box, designed to be easy-to-use and quick-to-deploy. A universal power kit and a range of mounting kits allow these systems to be placed in a wide range of locations.

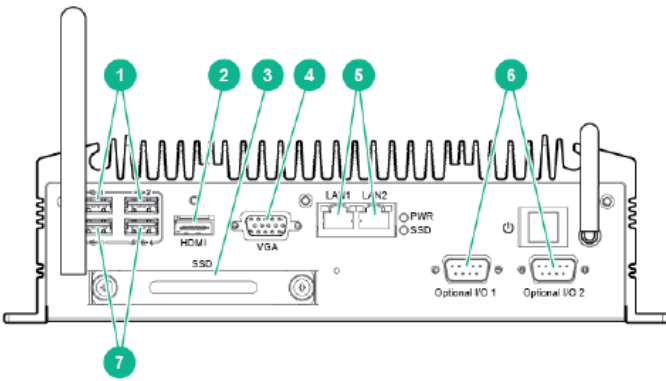

Front Panel Components

1. Two (2) USB 2.0 connectors
2. HDMI connector
3. SFF Drive bay
4. VGA connector
5. Two (2) LAN connectors
6. Two (2) serial port connectors (RS-232 or RS-422/485)
7. Two (2) USB 3.0 connectors

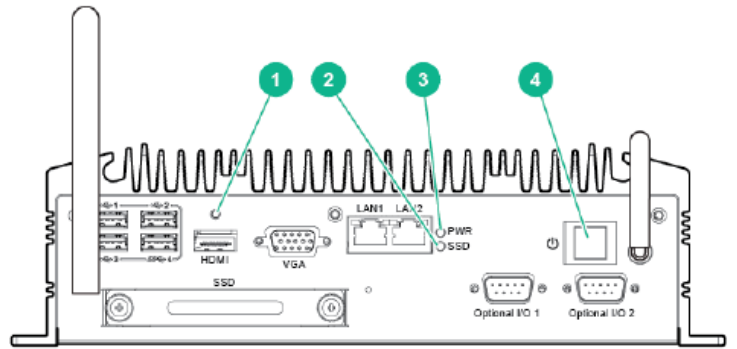

Front Panel LEDs and Buttons

1. Reset Button (indented)
2. Drive LED
3. Power LED
4. Power On/Off Button

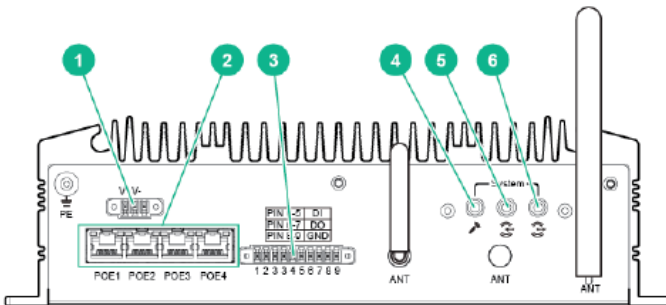

Rear Panel Components

1. DC input connector
2. Four (4) LAN connectors with PoE (10/100Mbps)
3. Digital I/O connector

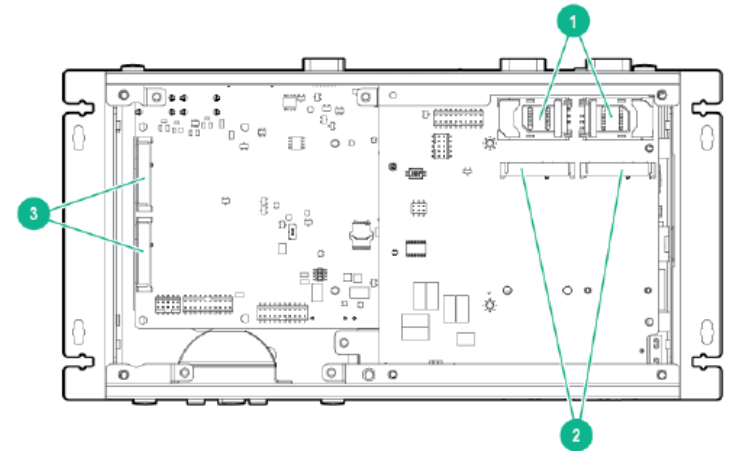

Expansion Board Components

1. SIM card holders (for slots #3 and #4)
2. Full-height mini-PCIe slots (#3 and #4)
3. Full-height (#1) and half-height (#2) mini-PCIe slots

Key features of HPE Edgeline Intelligent Gateways

- Purpose Built: HPE Edgeline Intelligent Gateways are ruggedized compute solutions designed to operate in a variety of edge environments – Industrial, Manufacturing, Smart Infrastructure, Oil & Gas etc.
- Optimum Configuration: Optimum CPU, memory, connectivity and expansive I/O selection addresses a host of IoT needs. Designed for Future Capabilities: Product designed to support a host of modular connectivity options that are customer upgradeable providing a strong foundation for future growth.
- Secure Platform: I/O Port Disablement, BIOS Password, Secure Boot. HPE Aruba software such as ClearPass to authenticate edge devices and secure VPN to protect remote connections
- Industrial Grade: Extended operating temperature -20°C to 60°C, Passively cooled, Shock and Vibration Tested, IP40 Certified
- Complete Solution: Easy-to-use and quick-to-deploy including a universal power kit (USA, UK, EURO and JPN) as well as universal mounting kit in support of DIN and wall mount applications.

Standard Features

The HPE Edgeline EL20 Intelligent Gateway offers the following unique benefits:

- Rugged performance-optimized edge gateway with additional features and higher compute capabilities to tackle more demanding large data volume deployments.
 - Optimally configured with an Intel i5 CPU, 8GB RAM, 64 GB SDD Storage . An expansive I/O selection including a 4 Port Power over Ethernet plus a 8-bit DIO enables PoE enabled peripherals as well as control of sensors and actuators.
 - Wide Voltage Solution: supporting 9 to 36 Volts DC input.
 - Designed for Future Capabilities: 4 mini-PCIe card slots enable a host of connectivity and I/O options that are customer upgradeable providing a strong foundation for future growth requirements.
-

Standard Features

Processor

Intel® Core™ Model	Base Frequency	Turbo Frequency	Cores	L3 Cache	Power	DDR3 MHz
I5-4300U	1.90 GHz	2.90 GHz	2	3 MB	15W	1600

NOTE: For more information regarding Intel® Core™, please see the following URL:
<http://www.intel.com/content/www/us/en/processors/core/core-processor-family.html>

Chipset

Integrated with SoC

Graphics

Intel® HD Graphics 4400 (GT2 generation, integrated with SoC)

Base: 200 MHz

Burst: 1.1 GHz

Maximum Video Memory: 2GB

Supports: DirectX11.1, OpenGL 4.0, and OpenCL 1.2; Full AVC/VC1/MPEG2 HW Decode

Memory

Type	DDR3 Small-Outline (SO-DIMM)	
Supported DIMMs	DDR3L-1600/1333 8GB (1R x 8)	
DIMM Slots Available	1	(1 DIMM slots per processor, 1 channels per processor, 1 DIMMs per channel)
Maximum Capacity (SO-DIMM)	8GB	(1 x 8GB SO-DIMM)

NOTES:

- The SoC supports 2 memory channels but a DIMM slot is available on only 1 channel
- Only 8GB SO-DIMMs are currently offered with this model, but it's compatible with 2GB/4GB SO-DIMMS.
- Registered DIMMs (RDIMMs), Load Reduced DIMMs (LRDIMMs) and Non-Volatile DIMMs (NVDIMMs) are not supported.

Expansion slots

One (1) Half-size mini-PCIe Expansion Slot - Slot #2

Three (3) Full-size mini-PCIe Expansion Slot

- Slot #1 can also be used for mSATA
- Slots #3 and 4 are connected to SIM card holders

NOTE: This system model is pre-wired with 4 antenna attach points for use with wireless module options.

Network Controller

Intel® i210IT - One (1) 10/100/1000 Mbps Ethernet Port with Wake-On-LAN (WoL) support

Intel® i218 - One (1) 10/100/1000 Mbps Ethernet Port with WoL support

NOTE: These 1GbE LAN ports in this system model do not support Power-over-Ethernet (PoE).

Four (4) 10/100 Mbps Ethernet Ports with PoE capability

- 4 ports full-load, IEEE802.3af Class 2 (7W)
- 2 ports full-load, IEEE802.3af Class 3 (15.4W)

Storage Controller and Devices

SATA controllers are Integrated in the Intel® Core™ SoC

Slot #	Technology	Bus Width	Connector Width	Form Factor	Supported Sizes
SFF Drive Bay	SATA-2	x1	x1	2.5" SFF	64 GB
mSATA Slot (shared with slot #1)	SATA-2	x1	x1	mSATA	N/A (Third-party)

Standard Features

NOTE: The SFF drive in this system model is hot-swappable. All operations to the drive must be stopped prior to servicing to prevent data loss.

Maximum Internal Storage	Drive Bay	64 GB	1 x 64 GB
	mSATA Slot	N/A (Third Party)	-

NOTE: This system is compatible with any SFF or mSATA drive, but only selected SSDs are currently offered.

Power Supply External AC 12V universal power supply kit (USA, UK, EURO and JPN) with lockable connector

Optional: 3-pin DC +9-36V input isolated to 1.5KV.

NOTE: If the direct DC input is used, a supply voltage of >10.9Vdc is recommended to ensure that full power can be supplied to the system

System Fans None. Passively cooled fanless product

Interfaces Two (1) RS-232 or RS-422/485 2-wire Serial Ports – switchable using BIOS; auto flow-control
Two (2) USB 2.0 Ports
Two (2) USB 3.0 Ports
One (1) VGA Port – supports 1920 x 1200 @ 154 Hz
One (1) HDMI Port – supports 3840 x 2160 @ 24 Hz
One (1) Audio In, One (1) Audio Out, One (1) Mic In – using Realtek ALC888S HD audio

Power On/Off Button & LED

Drive LED

System Reset Button

Digital I/O ports: Six (6) inputs and Two (2) Outputs

- Input Voltage: 0 to 30Vdc (25 Hz)
- Output Voltage: 24Vdc nominal in ON state (open collector to 30Vdc)
- Output Current: Max. 500mA per channel
- Isolated upto 3KV

Four (4) pre-wired antenna attach points for wireless module options

Operating System Support Microsoft Windows IoT Core
Microsoft Windows Server
Canonical Ubuntu Snappy Core
CentOS

NOTE: For more information on Hewlett Packard Enterprise's Certified and Supported systems for each OS and latest listing of software drivers available for your system, please visit our OS Support Site at: <http://www.hp.com/go/ossupport> and our driver download page which can be found from the HPE Support Center: <http://www.hpe.com/support/hpesc>

Industry Standard Compliance Microsoft® Logo certifications
USB 2.0 and 3.0 Support
ACPI 2.0 Compliant

International/Ingress Protection (IP): IP40 Certified

NOTE: IP40 – protected against ingress of objects such as tools and small wires >1mm, but not liquids.

Security I/O Port Disablement
BIOS Password
UEFI Secure Boot
HPE Aruba Secure VPN (for protecting remote connections)
HPE Aruba ClearPass (for authenticating edge devices)

Form Factor HPE Edgeline EL20 Intelligent Gateway is a standalone product.
Universal mounting kit allows for wall or DIN rail mounting. VESA kit is also bundled.

Warranty This product is covered by a global limited warranty and supported by Hewlett Packard Enterprise Services

Standard Features

and a worldwide network of Hewlett Packard Enterprise Authorized Channel Partners resellers. Hardware diagnostic support and repair is available for three years from date of purchase. Support for initial setup is available for 90 days from date of purchase. Enhancements to warranty services are available through customized service agreements.

NOTE: System Warranty includes 3-Year Parts, 0-Year Labor, 0-Year Onsite support with next business day response. Additional information regarding worldwide limited warranty and technical support is available at: <http://h20564.www2.hpe.com/hpsc/wc/public/home>

Configuration Information – Factory Integrated Models

NOTE:

This section lists some of the steps required to configure a Factory Integrated Model. To ensure only valid configurations are ordered, Hewlett Packard Enterprise recommends the use of a Hewlett Packard Enterprise approved configurator. Contact your local sales representative for information on configurable product offerings and requirements.

Step 1: Base Configuration (Choose System)

HPE Edgeline Gateway System HPE Edgeline EL20 Intel i5 1.9GHz 8GB 64GB 4POE w/o OS Intelligent Gateway 847910-B21

Step 2: Choose Factory Integration Options

Connectivity Modules (Min:0, Max:3) HPE Edgeline Wide Temperature Wi-Fi Option Kit 845779-B21

NOTES:

- Full-size mini-PCIe Card (FMC) with PCIe interface to system
- Supports wide operating temperature of -20°C to 60°C
- Wi-Fi Module supporting 802.11 a/b/g/n, 2.4/5.0 GHz, and 2x2 MIMO with dual-antennas. Speeds up to 300 Mbps.

HPE Edgeline Wide Temperature WAN 3G Option Kit 845788-B21

NOTES:

- Full-size mini-PCIe Card (FMC) with USB 2.0 interface to system
- SIM slot is located on the underside of the module
- Supports wide operating temperature of -20°C to 60°C
- 3G/3.75G (HSPA+) WAN module supporting dual antennas. Speeds up to 21.0 Mbps Download and 5.76 Mbps Upload.
- Supported frequencies: GSM | GPRS | EDGE: 850, 900, 1800, 1900 MHz, UMTS | HSPA: 800 / 850*, 900, AWS 1700,1900, 2100 MHz, * includes Bands B6 and B19 (800 MHz) as a subset of B5 (850 MHz)

Step 3: Choose Additional Options

NOTE: Some options may not be integrated at the factory.

Mounting Accessories N/A

NOTE: The HPE Edgeline EL20 Gateway is already bundled with a VESA mounting kit.

Technical Specifications

HPE Edgeline EL20 Intelligent Gateway

Chassis Dimensions (H x W x D)	Aluminum Housing 75.1 mm (2.96") x 264.5 mm (10.41") x 133.0 mm (5.24")
Weight	3.40 KG (7.5 lbs)
Power	Typical: 15W Maximum: 35W
Shock and Vibration	<p>Operational Shock 30 G, IEC 60068-2-27, half sine, 11 ms duration</p> <p>Operational Vibration 3 Grms, IEC 60068-2-64, random, 5 ~ 500 Hz, 1 hr/axis</p> <p>NOTE: Shock and Vibration testing conducted on a system configured with SSDs</p>
System Inlet Temperature	<p>Extended Operating -20° to 60°C (-4° to 140°F) at sea level with 0.7m/s air flow</p> <p>NOTE: Operating temperature range can be reduced if any non-wide temperature options are configured in the system.</p> <p>Non-Operating -40° to 85°C (-40° to 185°F)</p>
Relative Humidity	<p>Operating 5 to 95% relative humidity (Rh), 40°C (104°F) maximum wet bulb temperature, non-condensing</p> <p>Non-Operating 5 to 95% relative humidity (Rh), 40°C (104°F) maximum wet bulb temperature, non-condensing</p>
Acoustic Noise	None - Passively cooled solution with solid state drives
Emissions Classification (EMC)	<p>FCC Rating Class A</p> <p>Normative Standards CE/FCC Class A, CCC, BSMI</p> <p>NOTE: Product conformance to cited product specifications is based on sample (type) testing, evaluation, or assessment. This product or family of products is eligible to bear the appropriate compliance logos and statements.</p>

Summary of Changes

Date	Version History	Action	Description of Change
16-Dec-2016	From version 4 to 5	Update	Comprehensive updates to introduction, features and ordering menus
10-Jun-2016	From version 3 to 4	Updated	Update overall QuickSpecs information
22-Jan-2016	From version 2 to 3	Changed	Change the overview and the technical information section
18-Dec-2015	From version 1 to 2	Update	Address formatting of HPE Edgeline .
1-Dec-2015	Version 1	Created	Create the QS for the HPE Edgeline EL20 Intelligent Gateway Series



Sign up for updates



© Copyright 2016 Hewlett Packard Enterprise Development LP. The information contained herein is subject to change without notice. The only warranties for Hewlett Packard Enterprise products and services are set forth in the express warranty statements accompanying such products and services. Nothing herein should be construed as constituting an additional warranty. Hewlett Packard Enterprise shall not be liable for technical or editorial errors or omissions contained herein.

Microsoft and Windows NT are US registered trademarks of Microsoft Corporation. Intel, the Intel logo, Xeon and Xeon Inside are trademarks of Intel Corporation in the U.S. and other countries.

For hard drives, 1GB = 1 billion bytes. Actual formatted capacity is less.

c04884747 - 14500 - Worldwide – V5 – 16-December-2016